

Pennsylvania Classrooms for the Future

PolyVision Interactive Whiteboard Solution

Interact
Explore
Enlighten



Interactive Projection on a Touch-sensitive Surface



Optional Wireless Communication



Mobile Stand

PolyVision's TS Series of Interactive Whiteboards transform classrooms into more productive learning environments by supporting curriculum resources and engaging students.

Keep Your Class Engaged

Dramatically improve group interactivity by allowing students to collaborate and become engaged in classroom activities. PolyVision's TS Series digitally captures any notes written or projected onto the board, so your students can focus on the lesson content rather than concentrating on taking notes.

Maintain Message Consistency

There is little room for miscommunication when all session participants have the same notes; simply save your work for later distribution in your format of

choice: via email, Internet, intranet, or printed copies.

Enjoy your Free Time

Teachers who prefer a digital presentation format to a written format often spend a lot of time creating an interactive experience for their students. The TS series helps to eliminate the time crunch by capturing notes and annotations on projected images, so it's easy to review the notes made during previous sessions and digitally update presentations accordingly - an ideal solution for educators involved in either an activity or extended unit of study.

TS Series Interactive Whiteboards: Present an interactive experience.

POLYVISION[®]
A Steelcase Company

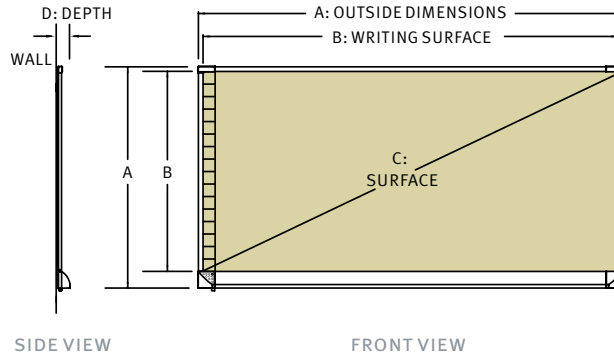

Interactive Whiteboard	Model TS 610 ET
Dimension A (HxW)	47.7" x 67.0" (1210mm x 1700mm)
Dimension B (HxW)	43.0" x 65.0" (1090mm x 1650mm)
Dimension C (Diagonal)	77.8" (1976mm)
Dimension D (Depth)	3.0" (76.2mm)
Resolution	8000 x 8000*
Weight	55 lbs. (24.97 kg)

*Exceeds specifications

Interactive Whiteboard

Surface material

Touch-sensitive, low-glare, stain-resistant Teflon® surface

Power Requirements

TS 610 ET USB powered

Certification

CE, FCC Class A

Software Features

- Transfer images via drag & drop, clipboard, or file export
- Anti-aliased markup including highlighters
- Real-time playback
- Multiple monitor support
- Save images in JPG, BMP, TIFF, WMF, HTM, PDF, PCT, MacPaint, PSD, PNG, Quicktime Image, and TGA
- RM Easiateach® and Webster included

Warranty

5 year on-site warranty

Accessories (Included)

- User guide
- 3.25" (830mm) round eraser
- Stylus
- 15' (5m) USB cable for TS 610 ET

Recommended Computer Requirements

Microsoft Windows®:

Windows 98, NT, 2000, ME, XP, or tablet XP

128 MB RAM

TS 610 ET one USB port

Apple Macintosh®:

Power PC or Intel processor

Mac OS 10.2 or higher

256 MB RAM (higher screen resolutions require more memory)

TS 610 ET one USB port

Optional Mobile Stand

Model

MS 610 ET

Dimensions

60" x 22.3" x 55" (L x W x H)

Board Model Supported

TS 610 ET

Board Size

4' x 6'

Height Adjustable

Yes

Number of Height Settings

3

Range of Adjustability

Max height w/ board 82"
Mid height w/ board 79.5"
Min height w/ board 77"

Stability Bar

Yes

Standard Wheel Size

2" diameter

Storage Shelf

56.5" x 16" (L x W)

Warranty

5 years

PolyVision Corporation

1.800.620.POLY

info@polyvision.com

www.polyvision.com

POLYVISION
A Steelcase Company